

Reg. No: _____

Name: _____

APJ ABDUL KALAM TECHNOLOGICAL UNIVERSITY
THIRD SEMESTER B.TECH DEGREE EXAMINATION, JANUARY 2017

Course Code: **EC201**

Course Name: **NETWORK THEORY (AE, EC)**

Max. Marks: 100

Duration: 3 Hours

PART A

Question No. 1 is compulsory. Answer Question 2 or 3

1. a. Use nodal analysis to find v_x in the circuit. (6)

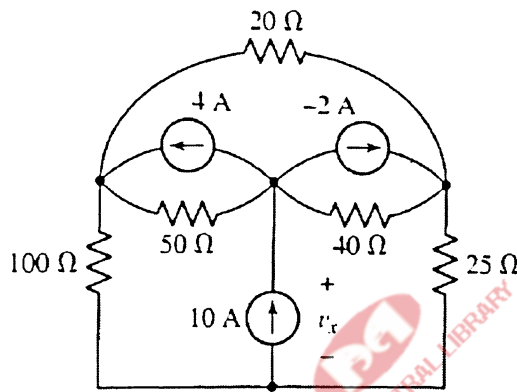

- b. Find the Thevenin equivalent of the network shown in figure. What power would be delivered to a load of 100 ohms at a and b ? (6)

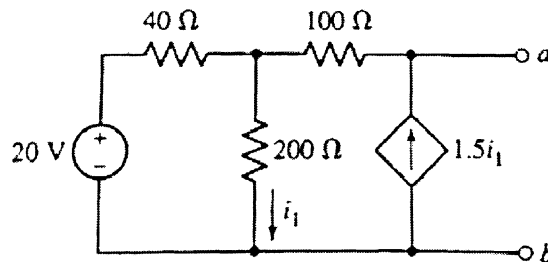

- c. State and prove maximum power transfer theorem. (3)
2. a. Obtain the expressions for the time-domain currents i_1 and i_2 in the circuit (8)

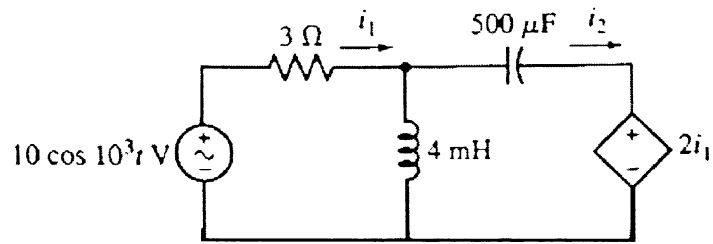

b. Explain source transformations and use it to determine the power dissipated by $1\text{M}\Omega$ resistance. (7)

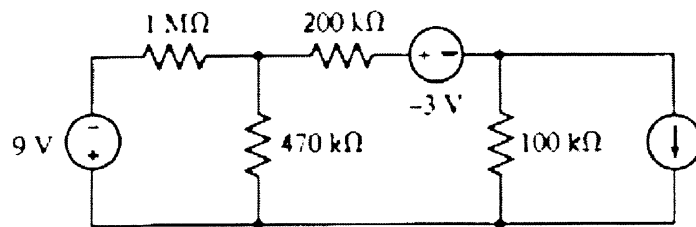

1. OR

3. a. Find the Thevenin equivalent circuit with respect to terminals a and b (9)

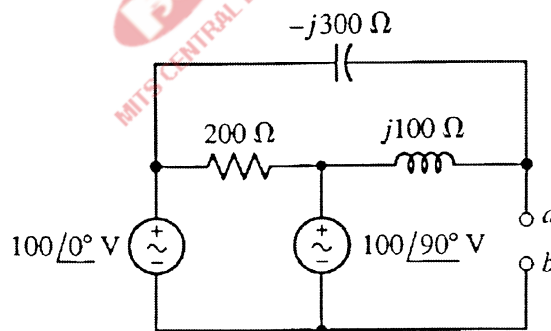

b. State and prove time differentiation and time integration theorems in Laplace Transform (6)

PART B

Question No. 4 is compulsory. Answer Question 5 or 6

- 4. a. Derive transient current and voltage responses of sinusoidal driven RL and RC circuits. (10)
- b. Explain how to determine the time domain behaviour from the pole - zero plot. (5)
- 5. a. Find the current $i_L(t)$ for all t after the switch opens. (8)

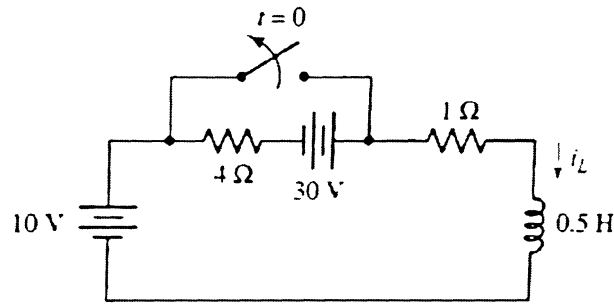

b. Find $v_C(t)$ for $t > 0$ in the circuit. (7)

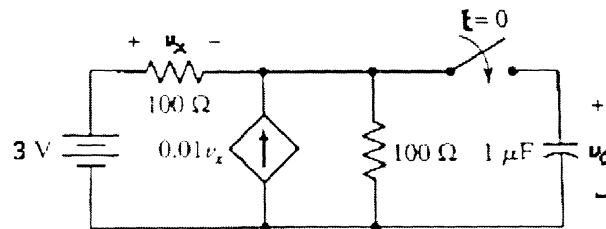

OR

6. What are the restrictions on pole and zero locations for transfer functions and driving-point functions. (15)

PART C

Question No. 7 is compulsory. Answer Question 8 or 9

- 7. a. Explain the series and parallel connection of two port networks. (8)
- b. Derive the interrelationship between transmission and hybrid two port network parameters. (6)
- c. For the network shown in figure find the resonant frequency. (6)

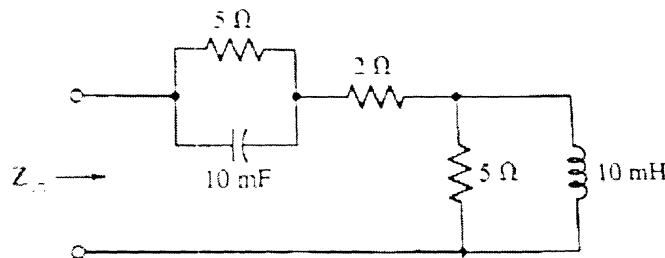

8. a. Find yparameters for the two-port network shown in figure. (6)

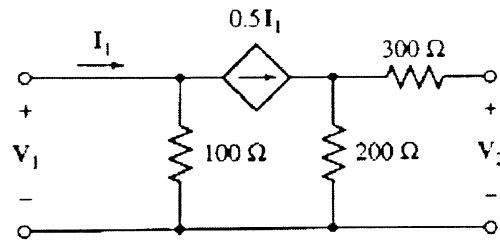

b. Calculate h parameters for the two-port network shown in figure. (7)

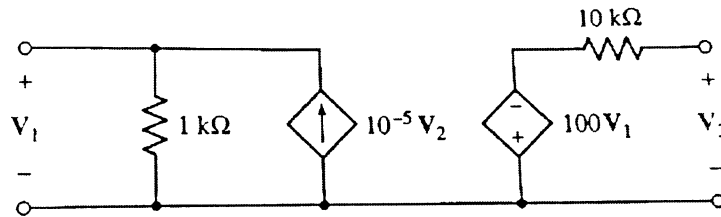

c. Calculate transmission parameters for the two-port network shown in figure. (7)

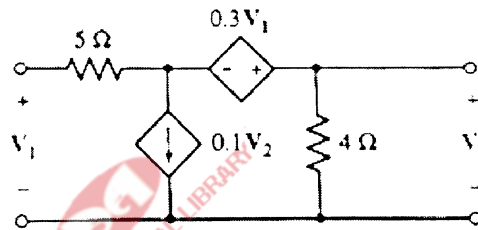

OR

9. a. Find V in the circuit. (4)

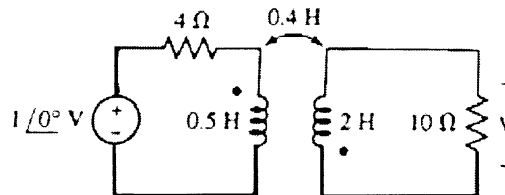

b. Find the time domain values of currents marked in the circuit. (10)

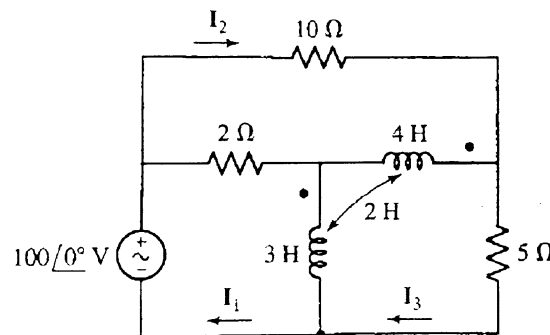

c. Explain the following terms (6)

- (i) Bandwidth
- (ii) Q-factor
- (iii) Selectivity