

Reg. No.

Name:

FIRST SEMESTER B.TECH DEGREE EXAMINATION, JANUARY 2016

Course Code: EE100

Course Name: BASICS OF ELECTRICAL ENGINEERING

Max. Marks: 100

Duration: 3 Hours

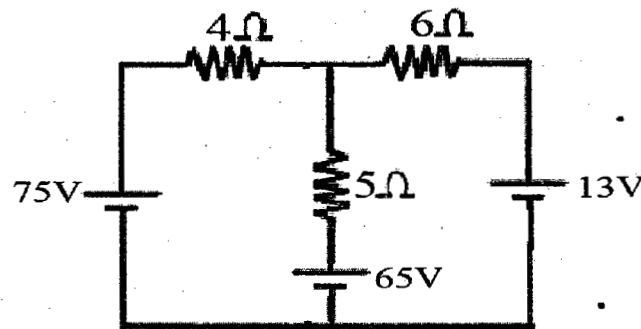
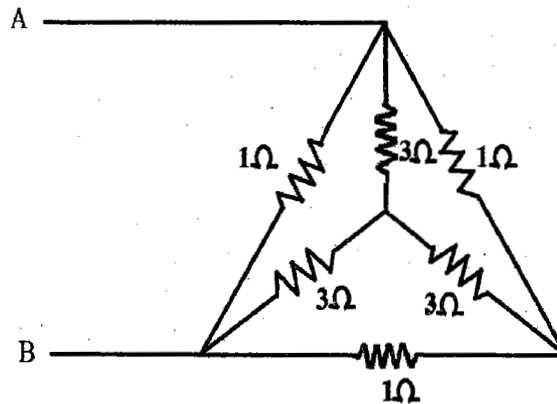
PART A*Answer all questions, each question carries 4 marks*1. Find the current through 5Ω resistor using Nodal analysis2. Determine the equivalent resistance R_{AB} using Star-Delta Transformation.

3. Differentiate between statically and dynamically induced emf.

4. Prove that the average power for a purely capacitive circuit is zero.

5. What are the advantages of three phase system over single phase system?

6. Give the reason for using high voltage in power transmission system.

7. What are the different types of losses in a transformer?

8. Single phase induction motor is not self-starting. Comment.

9. Draw the schematic layout of LT switch board.

10. 'Earthing is necessary'. Comment on the statement.

(10 x 4 = 40 Marks)

PART B

Answer any 4 FULL questions each having 10 marks

11. Calculate the current through the galvanometer

(10)

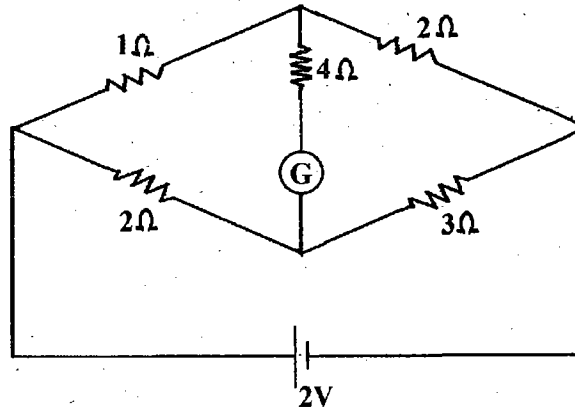

12. A steel ring of 25cm diameter and of circular cross section 3cm in diameter has an air gap of 1.5mm length. It is wound uniformly with 750 turns of wire carrying a current of 2.1 A. Calculate (i) m.m.f (ii) flux density in air gap (iii) magnetic flux (iv) relative permeability of steel ring. Assume that iron path takes about 35% of total magnetomotive force. (10)

13. Determine the form factor of the saw tooth wave shown: (10)

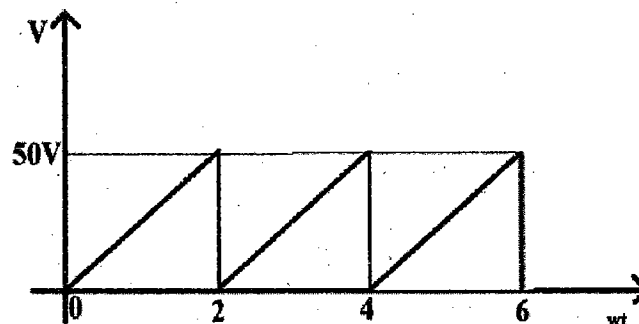

14. Explain how power is measured in a three phase system using two wattmeters. (10)

15. With a neat schematic diagram, explain a hydroelectric power generation plant. (10)

16. With a neat diagram, explain a typical power transmission scheme. (10)

(4x10=40 Marks)

Answer any one FULL question having 10 marks

17. With neat sketch give the construction details of a DC machine? (10)

OR

18. a) A single phase transformer has a core whose cross-sectional area is 150 cm^2 , operates at a maximum flux density of 1.1 Wb/m^2 from a 50Hz supply. If the secondary winding has 66 turns, determine the output KVA when connected to a load of 4Ω impedance. Neglect any voltage drop in transformer. (5)

b) The power input to a 230V dc shunt motor is 8.477kW. The field resistance is 230Ω and armature resistance is 0.28Ω . Find input current, armature current and back emf. (5)

Answer any one FULL question having 10 marks

19. a) Discuss the different tariff scheme employed for LT and HT consumers. (5)

b) With neat diagram, explain pipe earthing in electrical installation. (5)

OR

20. Discuss the difference between ELCB and MCB with neat diagram. (10)